

Maintenance sheet ATD2U 68Y103-2

A. Troubleshooting

If the error code is displayed on the remote controller, refer to Section B.

<< It takes long time to get hot water at the fixtures >>

- The time it takes to deliver hot water from the water heater to your fixtures depends on the length of piping between the two. The longer the distance or the bigger the pipes, the longer it will take to get hot water.
- If you would like to receive hot water to your fixtures quicker, you may want to consider a hot water recirculation system.

<< The water is not hot enough or turns cold and stays cold >>

- Compare the flow and temperature. Refer to the "Output temperature chart" of the Installation manual.
- Check cross plumbing between cold water lines and hot water lines.
- Check if the gas supply valve is fully open, the gas line is sized properly and the gas supplies enough pressure. Refer to the "Gas supply and gas pipe sizing" of the Installation manual.
- Check the set temperature, and change the set temperature with the remote controller or the DIPswitch setting. Refer to Section D.
- Refer to the "Water circuit" in this section.

<<The water is too hot>>

- Check the set temperature, lower setting temperature.

<<The hot water is not available when a fixture is opened>>

- Refer to the "Power supply circuit" and "Water circuit" in this section.

<<Fluctuation in hot water temperature>>

- Check if the filter on the cold water inlet is cleaned (Part #406).
- Check if the gas line is sized properly and the supply gas pressure is sufficient.
- Check for cross connection between cold water lines and hot water lines.
- Refer to the "Water circuit" in this section.

<<Unit does not ignite when water goes through the water heater>>

- Refer to the "Power supply circuit" and "Water circuit" in this section.
- If you use the remote controller, turn the power button on and then check if the STAND BY LED will light up.
- Check if the filter on the cold water inlet is cleaned (Part #406).
- Refer to the "Water circuit" in this section.

B. Error codes

031: Incorrect DIPswitch setting

- Check the DIPswitch settings on the PCB. Refer to Section D.

101: Warning for the "991" error code

- Check the gas type of the house (and/or the building). This model is only available for natural gas.
- Check if there is any blockage in the intake air and/or exhaust. Refer to the "Venting instructions" of the Installation manual.
- If the water heater is installed as a direct-vent system, check whether there is enough distance between the intake air terminal and the exhaust terminal. Refer to the "Vent termination clearances" of the Installation manual.
- Check the total vent length. Refer to the "Venting instructions" of the Installation manual.
- Check the altitude/elevation of area of where the water heater is installed. Refer to the "High-altitude function" of Section D. And change the DIPswitch settings.
- Check if there is grease and/or dirt in the burner (Part #101) and the fan motor (Part #103), especially if the water heater has been installed in a contaminated area.
- Check if there is dust and lint in the heat exchanger.
- Check the manifold pressure of the water heater. Refer to the Installation manual of the water heater.

111: Ignition failure

1. Check the gas supply and inlet gas pressure.
2. Check if the Hi-limit switch (Part #412) is properly functioning.
3. Check for connection/breakage of wires (Part #413, 708, 709, 712), and/or soot on the flame rod (Part #108). And then if the O.H.C.F (Part #413) has a breakage, **Consult the manufacturer.**
4. Check if there is a buzzing spark ignition sound coming from the burner (Part #101) when water heater prepares for combustion.
5. Listen for the double "clunk" sound coming from the gas valve assembly (Part #102) when water heater goes into combustion.
6. (Only if sparking and/or kick sound) Check the voltage on each wire to gas valve assembly (Part #102) and/or the igniter assembly (Part #711). Refer to "Appendix A" in Section C.
 - *No sparking sound >>>> Refer to #1 at "Appendix A" in Section C.
 - *No kick sound >>>> Refer to #2 at "Appendix A" in Section C.
7. Check if there is leaking from the heat exchanger (Part #401).
8. Check if there is dust and lint in nozzles of the manifold (Part #102).
9. Check the current on the flame rod (Part #108). Refer to #3 at "Appendix A" in Section C.

121: Loss of flame

1. Check the gas supply and inlet gas pressure.
2. Check if the Hi-limit switch (Part #412) is properly functioning.
3. Check for connection/breakage of wires (Part #413, 708, 709, 712), burn marks on the computer board (Part #701), and/or soot on the flame rod (Part #108). And then if the O.H.C.F (Part #413) has a breakage, **Consult the manufacturer.**
4. Check if there is leaking from the heat exchanger (Part #401).
5. Check if there is dust and lint in nozzles of the manifold (Part #102).
6. Check the current on the flame rod (Part #108). Refer to #3 at "Appendix A" in Section C.

311,321,331: Disconnected/short-circuited thermistor

- Check for connection/breakage of wires and/or debris on the thermistor (Part #407, 408, 411, 715).
- Check the thermistor resistance. Refer to "Appendix D" in Section C.

<<The fan motor is still spinning after operation has stopped>>

- This is normal. After operation has stopped, the fan motor keeps running from 15 to 70 seconds in order to re-ignite quickly, as well as purge all the exhaust gas out of the flue.

<<Abnormal sound from water heater>>

- An abnormal sound from the water heaters is caused by not enough air supply or wrong installations. The water heater needs more combustion air. Refer to the "101" error code in the section B.

<<Power supply circuit>>

1. If the remote controller is installed, press the "ON/OFF" button of the remote controller, and make sure that the STAND BY LED next to the "ON/OFF" button of the remote controller is lit. Restart the water heater.
2. Check if the green LED on the PCB (Part #701) of the water heater is lit. If so, the power supply circuit of the water heater is under normal condition. Next, refer to the "Water circuit" in this section.
3. Check the fuse on the surge box (Part #703), and if it has a brown spot, need to replace it.
4. Check the power supply, and make sure that the water heater has 120 VAC.
5. If the green LED on the PCB (Part #701) isn't lit, some electrical parts can be broken. **Consult the manufacturer.**

<<Water circuit>>

1. If you use the remote controller, turn the power button on and then check if the STAND BY LED will light up.
2. Open all hot water faucets, and make sure that there is enough water flow. This water heater needs at least 0.5 GPM water flow (at the default set temperature) to operate.
3. Check for reverse connection and cross connection.
4. Check if the filter on the cold water inlet is cleaned (Part #406).
5. Check if there is no debris or obstruction on the fixtures.
6. Check if water ways in the water heater are frozen. If so, unfreeze them. And refer to the Installation manual to protect your water heater from freezing.
7. Check if the inlet water pressure is higher than 40 psi. And if it's lower than 40 psi, need to increase the pressure.
8. Check for connections and breakage of wires (Part #402).
9. Check if the motor drive of the flow adjustment valve (Part #402) is locked due to scale buildup, and/or water leakage. If so, **Consult the manufacturer.**

391: Air-fuel ratio rod failure

- Check for connection/breakage of wires (Part #709) and/or soot on the flame rod (Part #108).

441: Flow sensor failure (Only Easy-Link system)

- Check for connection/breakage of wires and/or debris on the flow sensor impeller (Part #402).

510,551: Abnormal main gas solenoid valve and gas solenoid valve

- Check for connection/breakage of wires (Part #708) and/or burn marks on the computer board (Part #701).
- Reset power supply of the water heater.
- Check the voltage of each valve on the gas valve assembly (Part #102). Refer to "Appendix C" in Section C.

611: Fan motor fault

- Check for connection/breakage of wires, dust buildup in the fan motor (Part #103) and/or burn marks on the computer board (Part #701).
- Check for frozen/corrosion of connectors of the fan motor (Part #103).
- Check the voltage between blue wire and each wire of the fan motor (Part #103). Refer to "Appendix B" in Section C.

651: Flow adjustment valve fault (Only Easy-Link system)

- Inspect the flow adjustment valve (Part #402), for connection/breakage of wires, locked motor drive due to scale buildup, and/or water leakage.
- Check the voltage between black wire and red wire. Refer to "Appendix F" in Section C.

661: Bypass valve fault

- Inspect the bypass valve (Part #403), for connection/breakage of wires, locked motor drive due to scale buildup, and/or water leakage.
- Check the voltage between brown wire and red wire. Refer to "Appendix F" in Section C.

701: Computer board fault

- Check for connection/breakage of wires (Part #714), and check the resistance between white wire and red wire. Refer to "Appendix A" in Section C.

711: Gas solenoid valve drive circuit failure

- Refer to the "111" and "121" error codes in this section.

721: False flame detection

1. Clean the flame rod (Part #108).
2. For indoor models, check if a condensate drain is installed on the vent collar of the water heater.
3. Check if there is leaking from the heat exchanger (Part #401).

741: Miscommunication between water heater and remote controller

1. Check the model type of the remote controller. Model No. 9008172005 (TM-RE40) is the correct one.
2. Inspect the connections between the water heater and remote controller. Refer to the "Remote controller connections" of the Installation manual.
3. Check the power supply of the water heater.
4. If this error code appears only on the green LED in the PCB (Part #701), check the voltage on the remote controller terminal on the PCB. Refer to the "Appendix E" in Section C.
5. If this error code appears only on the remote controller, replace the PCB (Part #701).
6. If this error code appears on both the PCB (Part #701) and the remote controller, replace the remote controller.

761: Miscommunication between Parent unit and Child units for Easy-link system

- Check if the connections between the parent unit and the child units are correct. Refer to the "Easy-Link system" section in the Installation manual.

991: Imperfect combustion

- Refer to the "101" error code in this section.

C. Wiring diagram and check point of the water heater

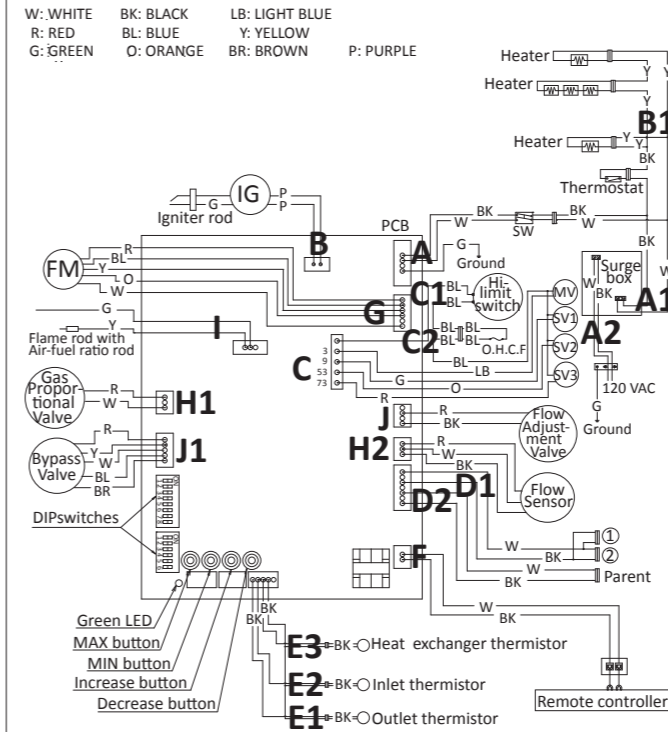

Appendix A (For error code 111)

Check the following points during ignition stage.

1. Refer to check point "B" on the wiring diagram above. Check the voltage between purple wires. (Normal: 108 to 132 VAC)
This check point is normal?
Yes >> Replace the igniter assembly (Part #711).
No >> Go to Next.
2. Refer to check points "C" and "H1" on the wiring diagram above. Check the voltages below:
 - C: Between blue wire and light blue wire (#3). (Normal: 93 to 120 VDC)
 - C: Between blue wire and orange wire (#53). (Normal: 93 to 120 VDC)
 - H1: Check the voltage between white wire and red wire. (Normal: 1 to 15 VDC)**These check points are normal?**
Yes >> Replace the gas valve assembly (Part #102).
No >> Replace the PCB (Part #701).
3. Check the current through the yellow flame rod wire (Part #709). (Normal: more than 5 μA)
This check point is normal during operation?
Yes >> Replace the PCB (Part #701).
No >> Replace the flame rod (Part #108).

Appendix B (For error code 611)

Refer to check point "G" in the diagram to the left and the following:

- Check the voltage between red wire and blue wire. (Normal: 132 to 192 VDC)
- Check the voltage between yellow wire and blue wire. (Normal: 13 to 17 VDC)
- Check the voltage between orange wire and blue wire. (Normal: 2.0 to 6.5 VDC)

All check points are normal?

- Yes >> Replace the fan motor (Part #103).**
- No >> Replace the PCB (Part #701).**

Appendix C (For error code 510 and 551)

Refer to check point "C" in the diagram to the left and the following. Check the voltage on the each valve on the gas valve assembly.

- Between blue wire and light blue wire (#3) (Normal: 93 to 120 VDC).
- Between blue wire and green wire (#9) (Normal: 93 to 120 VDC).
- Between blue wire and orange wire (#53) (Normal: 93 to 120 VDC).
- Between blue wire and red wire (#73) (Normal: 93 to 120 VDC).

All check points are normal?

- Yes >> Replace the gas valve assembly (Part #102).**
- No >> Replace the PCB (Part #701).**

Appendix D (For error code 311, 321 and 331)

- Outlet thermistor (Find the marking of No.113 on the connector) Check point "E1"
- Inlet thermistor (Find the marking of No.42 on the connector) Check point "E2"
- Heat exchanger thermistor (Find the marking of No.12 on the connector) Check point "E3"

Check the resistance between black wire and black wire.

Temperature	°F	50	59	68	77	86	95
	°C	10	15	20	25	30	35
Resistance	kΩ	15.4	12.6	10.3	8.5	7.0	5.9

All check points are normal?

- Yes >> Replace the PCB (Part #701).**
- No >> Replace the thermistor (Part #407, 408, 411).**

Appendix E (For error code 741)

Refer to check point "F" on the wiring diagram above.

J: Check the voltage between black wire and red wire. (Normal: 7 to 16 VDC)

J1: Check the voltage between brown wire and red wire. (Normal: 3 to 11 VDC)

This check point is normal?

- Yes >> Replace the remote controller.**
- No >> Replace the PCB (Part #701).**

Appendix F (For error code 651 and 661)

Refer to check point "J" or "J1" on the wiring diagram above.

J: Check the voltage between black wire and red wire. (Normal: 7 to 16 VDC)

J1: Check the voltage between brown wire and red wire. (Normal: 3 to 11 VDC)

This check point is normal?

- Yes >> Replace the Flow adjustment valve (Part #402), or Replace the Bypass valve (Part #403).**
- No >> Replace the PCB (Part #701).**

D. DIPswitch settings on the computer board of the water heater

Locate the two banks of DIPswitches at the bottom left of the computer board of the unit.

Change the DIPswitch settings when the power supply is turned off.

The dark square is the direction the DIPswitch should be set to. DEFAULT is the factory setting.

<Upper bank of DIPswitches>

Gas type	ON	1	2	3	4	5	6	7	8
Natural	ON	1	2	3	4	5	6	7	8
Gas	OFF	1	2	3	4	5	6	7	8

The Gas type DIPswitch should already be properly preset from the factory.

Model type (Vent length)

Indoor models (Vent length: 0 to 7 ft)	ON	1	2	3	4	5	6	7	8
	OFF	1	2	3	4	5	6	7	8
Indoor models (DEFAULT) (Vent length: 8 to 50 ft)	ON	1	2	3	4	5	6	7	8
	OFF	1	2	3	4	5	6	7	8
Outdoor models (DEFAULT)	ON	1	2	3	4	5	6	7	8
	OFF	1	2	3	4	5	6	7	8

<Lower bank of DIPswitches>

Temperature set	ON	1	2	3	4	5	6
120 °F (49 °C) (DEFAULT)	ON	1	2	3	4	5	6
	OFF	1	2	3	4	5	6
140 °F (60 °C)	ON	1	2	3	4	5	6
	OFF	1	2	3	4	5	6

Easy-Link system

Parent Unit	ON	1	2	3	4	5	6
	OFF	1	2	3	4	5	6
Child Unit (DEFAULT)	ON	1	2	3	4	5	6
	OFF	1	2	3	4	5	6

Single unit is the same as the child unit.

High-altitude function			
Indoor models		Outdoor models	
DEFAULT	ON 1 2 3 4 5 6 OFF 1 2 3 4 5 6	DEFAULT	ON 1 2 3 4 5 6 OFF 1 2 3 4 5 6
Up to 2,500 ft	ON 1 2 3 4 5 6 OFF 1 2 3 4 5 6	Up to 2,000 ft	ON 1 2 3 4 5 6 OFF 1 2 3 4 5 6
Up to 5,000 ft	ON 1 2 3 4 5 6 OFF 1 2 3 4 5 6	Up to 4,000 ft	ON 1 2 3 4 5 6 OFF 1 2 3 4 5 6
Up to 7,500 ft	ON 1 2 3 4 5 6 OFF 1 2 3 4 5 6	Up to 6,000 ft	ON 1 2 3 4 5 6 OFF 1 2 3 4 5 6
Over 7,500 ft	Consult the manufacturer	Over 6,000 ft	Consult the manufacturer

FM speed is increased automatically.

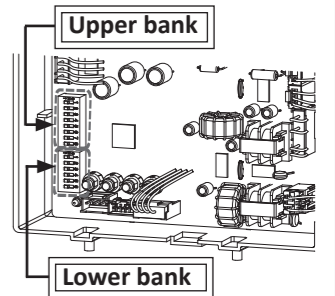

E. Components diagram / Parts list

Case assembly

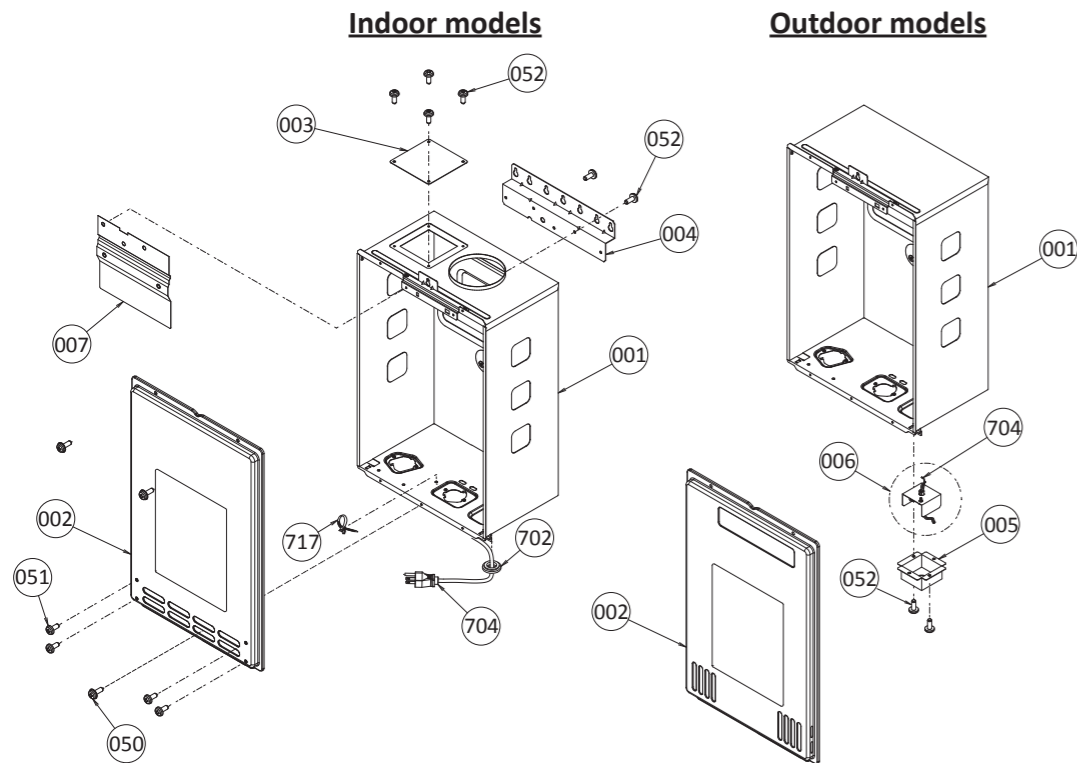

Item #	Part #		Description
	510U models	T-D2U models	
001	319143-428	EK103	Case assembly for Indoor models
	319143-429	EK111	Case assembly for Outdoor models
002	319143-432	EKD59	Front cover for Indoor models
	319143-433	EKD63	Front cover for Outdoor models
003	319143-150	EK401	Air blockage plate for Indoor models
004	319143-184	EKJ09	Bracket
005	319143-014	EKJ64	Junction box
006	319143-437	EKK4D	Power supply cord assembly
007	319143-221	EKK5H	Back guard panel
050	319143-025	EW000	Screw M4x12 (W/Washer)
051	319143-325	EW001	Screw M4x10 (W/Washer)
052	319143-026	EW002	Screw M4x10 (Coated)
053	319143-060	EW003	Screw M4x10
054	319143-326	EW004	Hex head screw M4x12 (W/Washer)
055	319143-063	EW005	Hex head screw M4x8
056	319143-327	EW008	Screw M3x10
057	319143-201	EKK31	Tap tight screw M4x12 FEZN
058	319143-087	EW00A	Screw M3x6
059	319143-328	EW009	Screw M4x6
060	319143-438	EKK37	Screw M4x12
061	319143-439	EW016	Screw M3x6
062	319143-440	EK155	Screw M4x8
063	319143-048	EM167	Wire clamp 60

Water way assembly

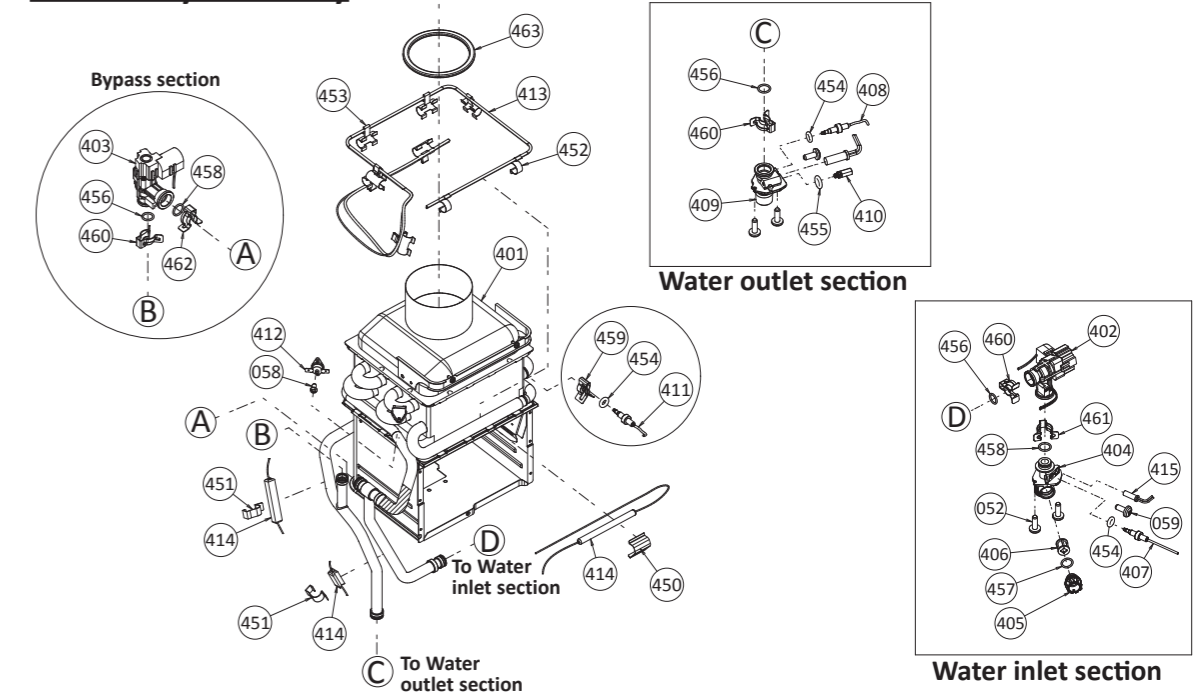

Burner assembly

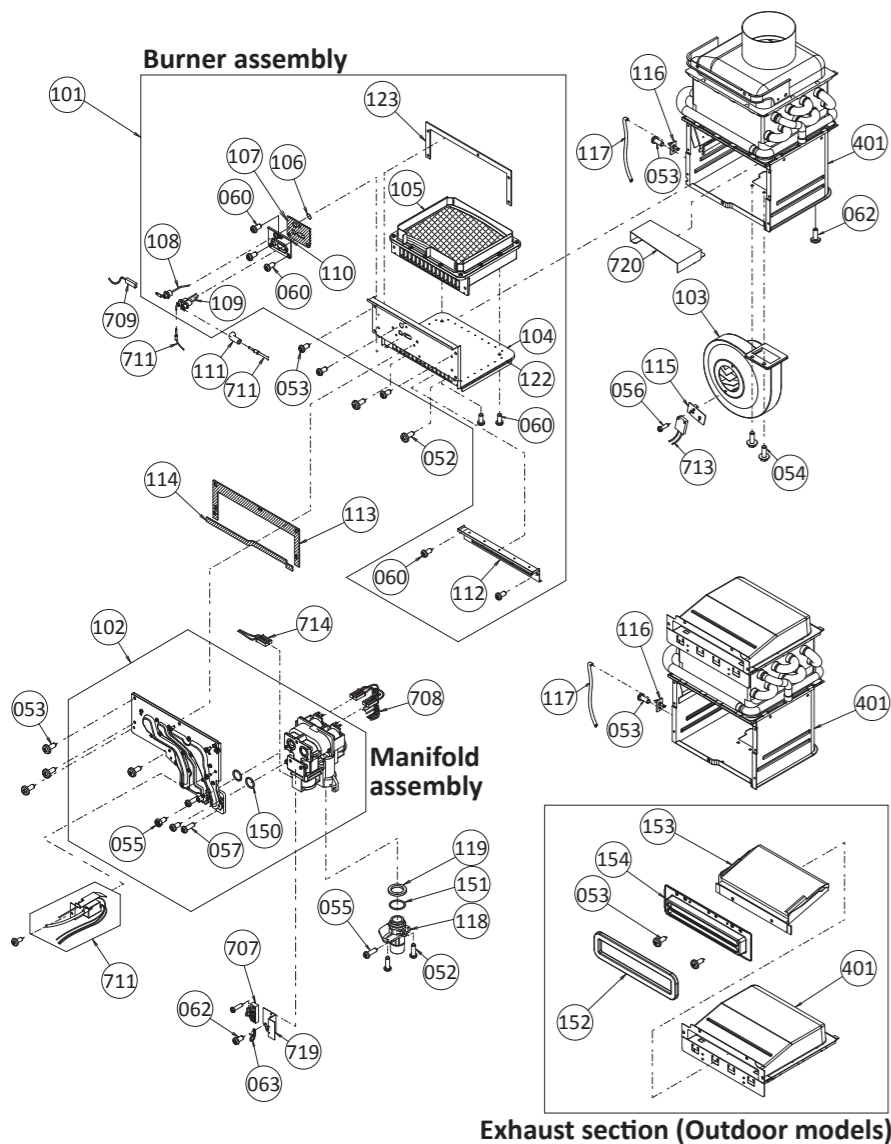

Computer board assembly

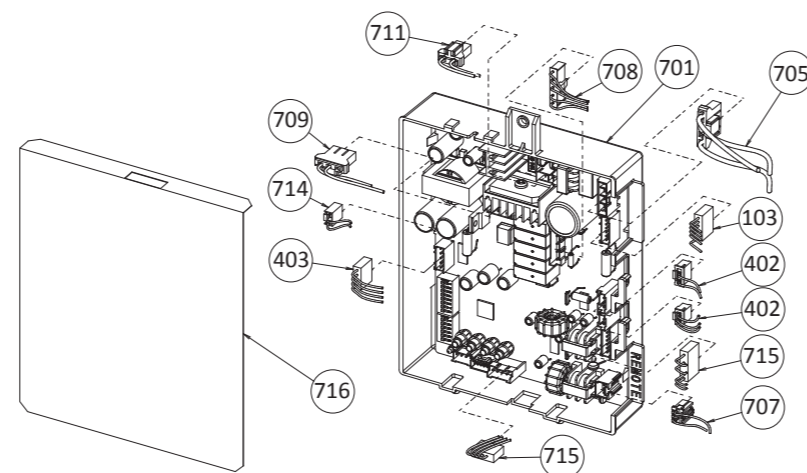

Item #	Part #		Description
	510U models	T-D2U models	
101	319143-441	EK120	Burner and mixing chamber assembly
102	319143-442	EK118	Manifold with gas valve assembly NA
103	319143-443	EK109	Fan motor for Indoor models
	319143-043	EKK25	Fan motor for Outdoor models
104	319143-444	EK144	Burner fixing plate assembly
105	319143-445	EK147	Burner and mixing chamber sub assembly
106	319143-033	EKK2V	Burner window
107	319143-446	EK107	Rod holder gasket
108	319143-447	EK125	Flame rod with AFR function
109	319143-448	EK124	Igniter rod
110	319143-449	EK126	Rod holder
111	319143-450	EK136	Rod cap
112	319143-451	EK116	Burner damper
113	319143-452	EK108	Manifold gasket A
114	319143-045	EKK2K	Manifold gasket B
115	319143-453	EK140	Fixing plate
116	319143-042	EKK2D	Pressure port
117	319143-454	EM482	Combustion chamber tube
118	319143-455	EK117	Gas inlet
119	319143-342	EX00D	Gas inlet ring
121	319143-176	EK436	Surge box plate
122	319143-456	EK127	Gasket
123	319143-457	EK145	Gasket
150	319143-350	EZP18	O-ring P18 NBR (Black)
151	319143-057	EK042	O-ring P20 NBR (Black)
152	319143-206	EKK3G	Silicon ring for Outdoor models
153	319143-458	EK134	Rain protection plate in Exhaust chamber for Outdoor models
154	319143-219	EKK56	Exhaust port for Outdoor models

Surge box

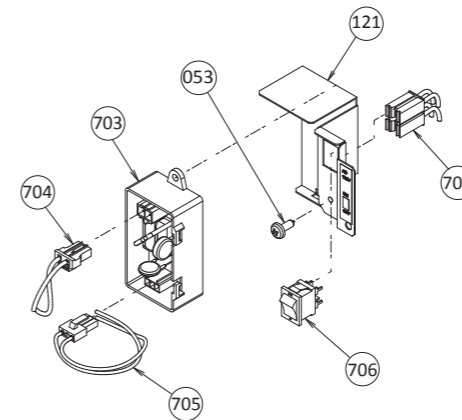

Temperature remote controller

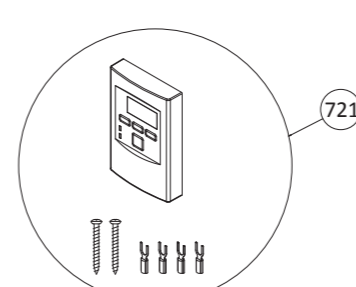

Item #	Part #		Description
	510U models	T-D2U models	
401	319143-461	EKD62	Heat exchanger assembly for Indoor models
	319143-462	EK122	Heat exchanger assembly for Outdoor models
402	319143-463	EK129	Flow adjustment valve / Flow sensor
403	319143-464	EKD58	Bypass valve
404	319143-193	EKK1U	Water inlet
405	319143-197	EKK2B	Inlet drain plug
406	319143-198	EKK2C	Inlet water filter
407	319143-465	EK137	Inlet thermistor
408	319143-190	EKK1A	Outlet thermistor
409	319143-466	EK104	Water outlet
410	319143-199	EKK2E	Outlet drain plug
411	319143-096	EKK2T	Heat exchanger thermistor
412	319143-095	EKN34	Hi-Limit switch
413	319143-149	EK333	Overheat-cut-off fuse
414	319143-467	EK130	Pipe heater
415	319143-468	EK105	Inlet heater
450	319143-088	EKK27	Pipe heater fixing plate
451	319143-125	EK031	Heater fixing plate 16
452	319143-066	EKK26	Fuse fixing plate 18
453	319143-146	EK029	Fuse fixing plate 14
454	319143-082	EZM04	O-ring P4 FKM
455	319143-080	EZM06	O-ring P6 FKM
456	319143-100	EZM14	O-ring P14 FKM
457	319143-091	EZM15	O-ring P15 FKM
458	319143-083	EZM16	O-ring P16 FKM
459	319143-097	EKH30	Fastener "4-11"
460	319143-105	EKK24	Fastener "14-22"
461	319143-226	EM192	Fastener "16A"
462	319143-205	EKK39	Fastener "16-25A"
463	319143-065	EKN50	Silicon ring for Indoor models
701	319143-471	EK149	Computer board
702	319143-426	EK148	Rubber grommet for Indoor models
703	320273-128	EK280	Surge box
704	319143-427	EK146	120 VAC wire for Indoor models
	319143-138	EKK3C	120 VAC wire for Outdoor models
705	319143-472	EK115	Switch wire
706	319143-141	EKK4V	120 VAC Power ON-OFF switch
707	319143-474	EKD61	Remote controller wire
708	319143-475	EK114	Gas valve wire
709	319143-477	EKD64	Flame rod wire
711	319143-479	EK153	Igniter assembly
713	319143-185	EKJ59	Freeze protection thermostat
714	319143-481	EK112	Proportional gas valve wire
715	319143-482	EKD60	24V cables
716	319143-191	EKK1M	Computer board cover
717	319143-425	EW022	Cable strap for Indoor models
719	319143-484	EK152	Remote fixing plate
720	319143-489	EK156	Flow adjustment plate
721	319143-485	ER014	Temperature remote controller