

PRODUCT PRESERVERS® ANTI-SCALE SYSTEM

THE PRODUCT PRESERVERS® ANTI-SCALE SYSTEM IS DESIGNED TO PROTECT YOUR TANKLESS WATER HEATER FROM THE DAMAGING EFFECTS OF HARD WATER SCALE

WHAT IS HARD WATER SCALE:

- More than 85% of American homes have hard water with high mineral content (generally magnesium and calcium)
- These minerals can precipitate out of the water leaving behind a solid mineral deposit called hard water scale.
- Scale acts as a thermal insulator preventing full transfer of heat from the burner into the water reducing the efficiency of the water heater.
- Hard water scale can lead to overheating and eventually damage to the water heater components.

HOW IT WORKS:

- As water flows through the filter, minerals form into inactive scale crystals.
- This inactive form of scale flows through the tankless water heater without sticking to any components.
- This system can even reduce scale formation on other hot water appliances and fixtures.

BENEFITS:

- Provides active protection against scale formation so there is no requirement to flush/descale the tankless water heater.
- Does not add chemicals to the water or require electricity.
- Virtually maintenance free; one simple filter change every two years to ensure continuous protection from the effects of hard water scale.

LIMITED WARRANTY:

- The Product Preservers® cartridge systems have a limited warranty to be free of defects in materials and workmanship for two years from the date of original shipment.
- Product Preservers® filter cartridges have a limited warranty for performance for a period of two years from the date of original installation when installed and operated in accordance with the instructions in the corresponding Installation and Operation Manual.



MODEL: PP-AS20

Connection Size	Operating Pressure Range	Replacement Cycle	Operating Temperature	Rated Flow	Weight
3/4" NPT	20-100 psi	2 years	40-100°F	7 gpm	5.6 lbs

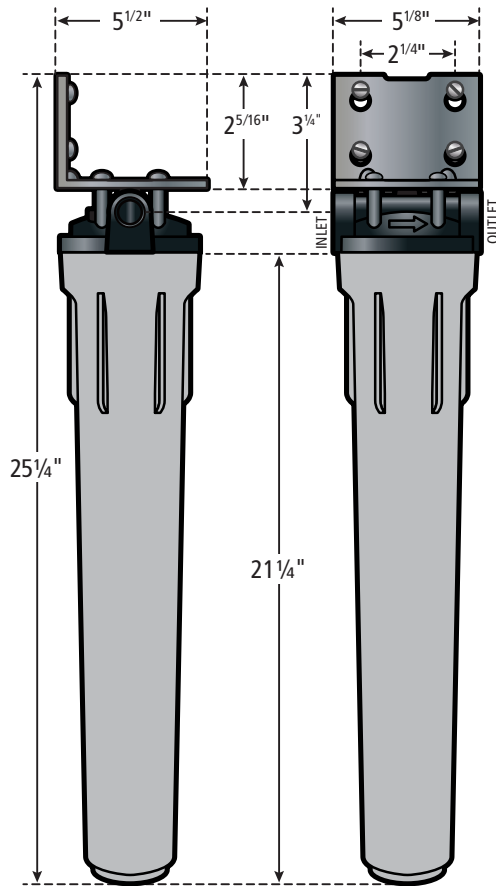

Model	Part Number
PP-AS20 Anti-Scale System	100291509
PP-AS20R Replacement Cartridge	100291510

WATER QUALITY GUIDELINES:

Hardness: ≤45 grains
Chlorine: ≤2.0 ppm

OPERATING RECOMMENDATIONS:

- Please read installation instructions carefully and completely before installing unit.
- Install on cold water lines only.
- Install unit in a vertical, upright, and level position.
- Allow a minimum of 3" under the system for filter cartridge replacements.
- Replace filter cartridge every 2 years.

SPECIFICATION

Product Preservers® Anti-Scale System shall be installed on the cold water line upstream of the tankless water heater. A Product Preservers® system may also be used to protect multiple appliances as long as the combined peak flow rate for all appliances is less than the rated flow of the Product Preservers® system. The system shall be plumbed with a bypass line to allow continued appliance operation during filter service or replacement. The Product Preservers® system should be installed in an area with sufficient clearance for filter replacements and should be installed per the installation manual provided with each system.

For technical information call 800-527-1953. A. O. Smith Corporation reserves the right to make product changes or improvements without prior notice.